



The flexible capabilities of the Tyreflex Coupling help to accommodate angular, parallel and axial misalignments.

Parallel Misalignment upto 6 mm. Angular Misalignment upto 4°. End Float upto 8 mm. Suitable in ambient temp. upto 70°C.

CUSHIONING SHOCK LOADS

Tyreflex being a torsionally soft coupling protects against vibration, impact loads and heavy shocks in the event of sudden load changes.

EASE OF ASSEMBLY / DISASSEMBLY

Alignment is quickly checked by placing a straight edge across the outside diameters of the flanges.

Installation or replacement of new tyre is achieved without disturbing driver or driven shafts, simply by loosening the clamping screws, placing a new tyre between the flanges and clamping rings and then tightening the clamping screws.

TYRE-FLEX COUPLING - RST

Tyre-flex Spacer Couplings RST are specifically designed for motor-pump installations, where it is desirable not to disturb drive/driven equipment while servicing impellers, packing glands, etc.

The maintenance time-reduction feature is valuable on pumps, compressors and many other applications.

It comprises of a spacer assembly and a standard Tyre-flex coupling. The spacer assembly consists of a flanged shaft and a spacer adapter taper bored to suit standard Taper Bush.

SELECTION PROCEDURE - T/TO

(a) Service Factor

Determine the required service factor from table 1.

(b) Design Power

Multiply the normal running power by the service factor. This gives **Design Power** which is used as a basis for selecting the coupling.

(c) Coupling Size

Refer table 2 and from the appropriate speed read across until a power greater than that required is found. The size of Tyre-flex coupling required is given in that column..

(d) Bore Size

Check from table 3 that selected coupling can accommodate required bores.

SELECTION PROCEDURE - RST

1. Select a suitable size of Tyre-flex coupling using the procedure.
2. Refer size column in table A and locate the size of coupling selected.
3. Read across this size until required DBSE can be accommodated.
4. The size of the spacer coupling is given in the first column of table A.
5. Refer coupling dimensional table A to check that the required bores can be accommodated.

TABLE 1 : SERVICE FACTORS

SPECIAL CLASSES For applications where substantial shock, vibration and torque fluctuations occur and for reciprocating machines e.g. internal combustion engines, piston pumps and compressors, refer to Rathi Transpower Pvt. Ltd. with full application details for analysis.	Type of Driving Unit					
	Electric Motors Steam Turbines			Internal Combustion Engines Steam Engines Water Engines		
	Hours per day duty			Hours per day duty		
Type of Driven Machine	upto 10	over 10 to 16 incl.	Over 16	upto 10	over 10 to 16 incl.	Over 16
CLASS 1 Agitators, Brewing mahinery, Centrifugal compressors and pumps, Belt Conveyors, Dynamometers, Lineshafts, Fans upto 7.5 kW, Blower and exhausters (except positive displacement), Generators.	0.8	0.9	1.0	1.3	1.4	1.5
CLASS 2 Clay working machinery, General machine tools, Paper mill beaters and winders, Rotary pumps, Rubber extruders, Rotary Screens, Textile Machinery, Marine Propellers, and Fans over 7.5 kW.	1.3	1.4	1.5	1.8	1.9	2.0
CLASS 3 Bucket elevators, Cooling tower fans, Piston compressors & pumps, Foundry machinery, Metal presses, Paper mill Calenders, Hammer mills, Presses and pulp grinders, Rubber Calenders, Pulverisers and Positive displacement blowers.	1.8	1.9	2.0	2.3	2.4	2.5
CLASS 4 Reciprocating conveyors, Gyrotory crushers, Mills (ball, pebble and rod). Rubber Machinery (Banbury Mixers and Mills) and Vibratory screens.	2.3	2.4	2.5	2.8	2.9	3.0

TABLE 2: POWER RATING (kW)

Speed rpm	Size T / TO														
	4	5	6	7	8	9	10	11	12	14	16	18	20	22	25
100	0.25	0.69	1.33	2.62	3.93	5.24	7.07	9.16	13.9	24.3	39.5	65.7	97.6	121	154
750	1.87	5.17	9.97	19.65	29.47	39.30	53.02	68.70	104.25	182.25	296.25	492.75	732	907.5	1155
1000	2.50	6.90	13.30	26.20	39.30	52.40	70.70	91.60	139.0	243.0	395.0	657.0	976	1215	1537
1500	3.75	10.35	19.95	39.30	58.95	78.60	106.05	137.40	208.50	364.50	592.50*	986.5*	-	-	-
1800	4.50	12.42	23.94	47.16	70.74	94.32	127.26	164.88	250.20	437.40*	-	-	-	-	-
3000	7.50	20.70	39.90	78.60	117.90*	157.20*	-	-	-	-	-	-	-	-	-
3600	9.00	24.84	47.98	94.32	-	-	-	-	-	-	-	-	-	-	-

- All these power ratings are calculated at constant torque.
- For speeds below 100 rpm and intermediate speeds use normal torque ratings.
- * Dynamic balancing preferred at these speeds.

Poles	2	4	6	8
rpm	3000	1500	1000	750

TECHNICAL DATA : FLEXIBLE TYRES

Size	4	5	6	7	8	9	10	11	12	14	16	18	20	22	25
Max. Speed rpm	4500	4500	4000	3600	3100	3000	2600	2300	2050	1800	1600	1500	1300	1100	1000
Torsional Stiffness Nm/Deg.	5	13	26	41	63	91	126	178	296	470	778	1371	1959	2760	3562
Parallel Misalignment mm	1.1	1.3	1.6	1.9	2.1	2.4	2.6	2.9	3.2	3.7	4.2	4.8	5.3	5.8	6.6
End Float mm	1.3	1.7	2.0	2.3	2.6	3.0	3.3	3.7	4.0	4.6	5.3	6.0	6.6	7.3	8.2
Normal Torque Nm	24	66	127	250	375	500	675	875	1330	2325	3730	6270	9325	11600	14675
Max. Torque Nm	64	160	318	487	759	1096	1517	2137	3547	5642	9339	16455	23508	33125	42740

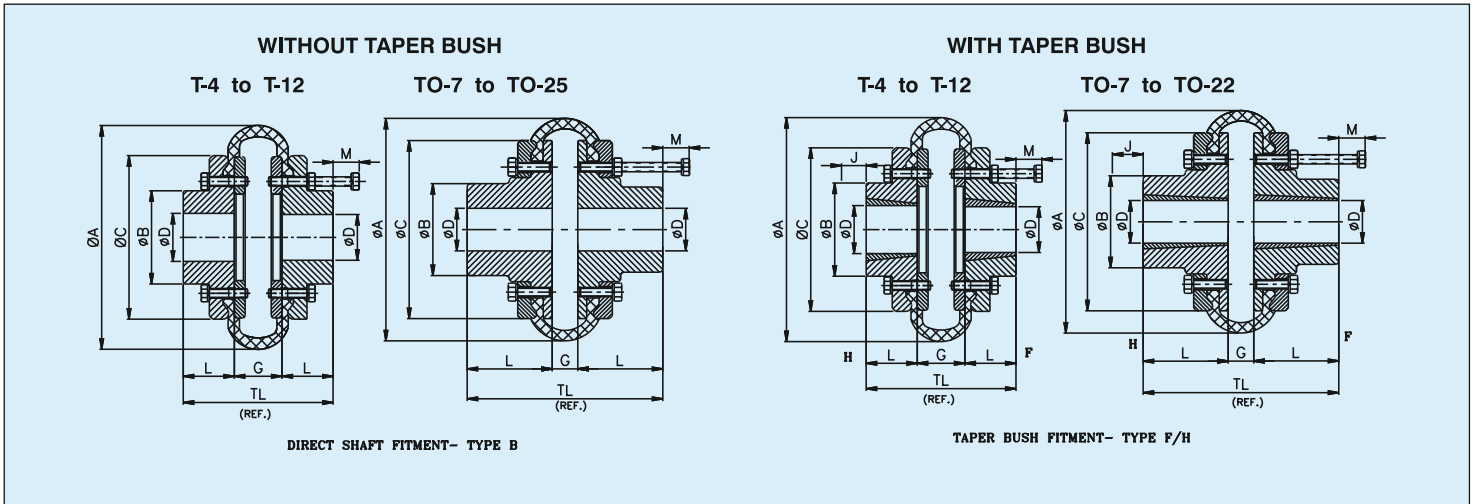

TABLE 3 : DIMENSIONS OF TYRE-FLEX HUB TYPES B, F & H

COUPLING SIZE	KW @ 100 RPM	MAX. SPEED (RPM)	TYPE	# BUSH SIZE	BORE ØD		# TYPE F/H			TYPE B		ØA	ØB	ØC	G	M	WT.(Kg)	M.I. (WR ²) Kg-m ²
					PB	MAX.	TL	L	J	TL	L							
T-4	0.25	4500	B	-	10	32	-	-	-	68	22	104	-	82	24	17	1.9	0.00161
			F/H	1008	-	25	68	22	29	-	-							
T-5	0.69	4500	B	-	10	38	-	-	-	93	32	133	79	100	29	17	3.5	0.00358
			F/H	1210	-	32	79	25	38	-	-							
T-6	1.33	4000	B	-	15	45	-	-	-	111	38	165	73	125	35	8	5	0.0105
			F/H	1610	-	42	85	25	38	-	-							
T-7	2.62	3600	B	-	19	50	-	-	-	133	45	197	77	144	43	-	7.8	0.0198
T-8	3.93	3100	B	-	25	63	-	-	-	150	51	210	96	167	48	-	10.9	0.042
T-9	5.24	3000	B	-	30	75	-	-	-	165	57	235	110	188	51	-	15	0.0681
T-10	7.07	2600	B	-	32	80	-	-	-	178	60	254	125	216	58	-	21.5	0.1303
T-11	9.16	2300	B	-	32	90	-	-	-	183	65	279	140	233	53	-	28.8	0.1622
T-12	13.90	2050	B	-	38	100	-	-	-	210	76	314	152	264	58	-	43.1	0.365
TO-14	24.30	1800	B	-	58	125	-	-	-	210	89	359	195	311	32	26	60.6	0.6045
			F/H	3525	-	90	162	65	67	-	-							
TO-16	39.50	1600	B	-	65	140	-	-	-	234	102	395	216	345	30	-	86.4	1.2755
			F/H	4030	-	100	184	77	80	-	-							
TO-18	65.70	1500	B	-	70	150	-	-	-	278	116	470	220	398	46	-	133.3	2.1525
			F/H	4535	-	115	224	89	89	-	-							
TO-20	97.60	1300	B	-	70	150	-	-	-	276	114	508	220	429	48	-	144.6	3.1765
			F/H	4535	-	115	226	89	89	-	-							
TO-22	121	1100	B	-	75	160	-	-	-	308	127	562	240	470	54	-	181.63	4.7861
			F/H	5040	-	125	258	102	92	-	-							
TO-25	154	1000	B	-	85	190	-	-	-	324	132	628	275	532	60	-	281.1	8.129

NOTES:

- 1) All Dimensions are in mm .
- 2) M is amount by which clamping screw need to be withdrawn to release tyre .
- 3) J is wrench clearance to allow for tightening and loosening of the bush on the shaft.
- 4) Shaft ends, although normally located G apart can project beyond flanges.
- 5) Weight & Moment of inertia specified for solid bores.
- 6) F/H construction for size 7 to 12 available in TO-07 to TO-12.
- 7) # Available only with taper bore, without taper bush.
- 8) FRAS (fire resistance antistatic) Tyres are available on request.

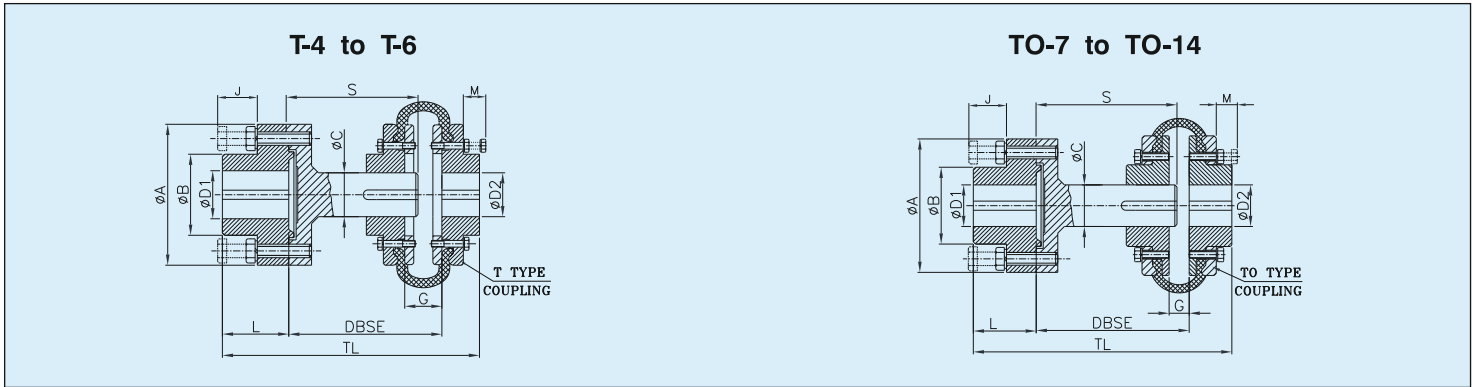

TABLE A : DIMENSIONAL DATA

SPACER SIZE	TYPE	NOM. DBSE	BORE ØD1		ØA	ØB	TL		L	J	S		ØC	TYRE FLEX SIZE T/TO	BORE ØD2		G		M
			PB	MAX.			T	TO			T	TO			PB	MAX.	T	TO	
RST-12	B	80 100	10	42	118	83	127 147	- -	25	22	57 77	-	25	4	10	32	24	-	17
RST-16	B	100	18	48	127	80	160	-	38	24	94	-	32	4	10	32	24	-	17
		200					134				4			10	32	24	17		
		170					94				5			10	38	29	17		
		210					134				5			10	38	29	17		
		176					94				6			15	45	35	8		
216	134	6	15	45	35	8													
RST-25	B	100	38	80	178	127	190	-	45	27	94	48	48	7	19	50	16	-	-
		230					134				7			19	50	16	-		
		270					174				7			19	50	16	-		
		196					94				8			25	63	22	10		
		236					134				8			25	63	22	10		
		276					174				8			25	63	22	10		
		242					134				9			30	75	24	-		
		282					174				9			30	75	24	-		
RST-30	B	140	40	90	216	146	276	-	76	33	134	60	60	10	32	80	24	-	-
		316					174				10			32	80	24			
		281					134				11			32	90	22			
		321					134				11			32	90	22			
RST-35	B	140	66	110	248	178	305	-	89	33	134	80	80	12	38	100	25	-	-
		345					174				12			38	100	25			
		358					174				14			58	125	32	26		

NOTES :-

- 1) Special Spacers are available on request.
- 2) Refer Installation Instructions for Mounting and Dismounting.
- 3) For Tyre coupling details, please refer tyre coupling catalogue.

In view of our constant endeavour to improve quality of our products, we reserve the right to alter or change specifications without prior notice. This document is the intellectual property of Rathi Transpower Pvt. Ltd. and subject to copyright.



Rathi Transpower Pvt Ltd
Gaia Apex, S. No. 33/2D, Viman Nagar
Pune 411 014.(INDIA)

Distributor



79/1, APS Complex, Iduvampalayam Road,
Periyandipalayam Tiruppur-641687, India
Mobile: 90477 77573, Tel : 0421 4955647
Email: sales@kbandtraders.com.
Web: www.kbandtraders.com