

Lovejoy Grid-*f*lex couplings are lubricated, having high torque capacity like gear couplings & with torsional flexibility of an Elastomer couplings. Grid-*f*lex offers the simplest, most cost effective solution for moderate to high torque application.

FEATURES :

SIMPLICITY

Has few components such as Hubs, Grid, Cover, Seal & Fasteners.

- **Hubs** are made from high fatigue strength steel, so that tooth fatigue failures are eliminated. Hubs are accurately machined to permit utilization of any hub surface for measurement of shaft alignment.
- **Grid** is made from high strength spring steel and duly heat treated to get high hardness. So that the stresses developed in the grid by transmitted load are well below the design value. Both straight & taper grids are available.
- **Covers** are made of Graded Cast Iron / Aluminium covers which permit higher running speeds.
- **Seal** is specially “U” shaped and made of synthetic material to withstand oil, dusty atmosphere and prevent leakage of lubricant.
- **Fasteners** are made of High tensile grade materials.

SIMPLE / EASY MAINTENANCE

As there are fewer & less complicated components, maintenance is less & when regular inspection / lubrication is done the couplings gives good life.

Service Factor :



LOW OPERATIONAL COST

The spare required is mainly the grid, which is a low cost component and that also gives substantial life. Hence the operational cost is much low.

SMOOTH & QUIET OPERATION

The coupling components except grid to hub have no relative movement. Hence are smooth is operation. In grid & hub also the relative movement is very low & depends on misalignment. Hence the coupling as a whole is smooth & quite in operation.

LUBRICATION

Rathi Special Grease (RSG) is developed to resist separation of base oil & thickener due to centrifugal forces encountered in Grid coupling to avoid wear & tear.

Class of Machine	S.F.	Class of Machine	S.F.
Agitator	2	Fan	2.5
Calender	3	: Cooling tower	2.0
Cement Mill & Kiln	3	: Industrial	2.5
Conveyor		: Mine	3
: Horizontal	1.0	Haulage	2
: Inclined	1.5	Line Shafting	3.0
Couches	2.5	Machine Tool	1.5
Crane motions :-		: Reversing	2~4
a) (Classes 3 & 4)		: Other	1.25
Hoist	4	Pumps	2
Long travel	3	: Centrifugal	3
Cross traverse	3	: Rotary	4
b) (Classes 1 & 2)		: Reciprocating	3
Hoist	3	Rock Crushers	4
Long travel	2.5	Rubber Mill	3
Cross traverse	2.5	Steel Work Drives	2~5
Electric Generator (Steady load)	1.75	Turbine Driven Generators	1.25
		Rolling Mills, Motors Driven	4
		without Flywheel	

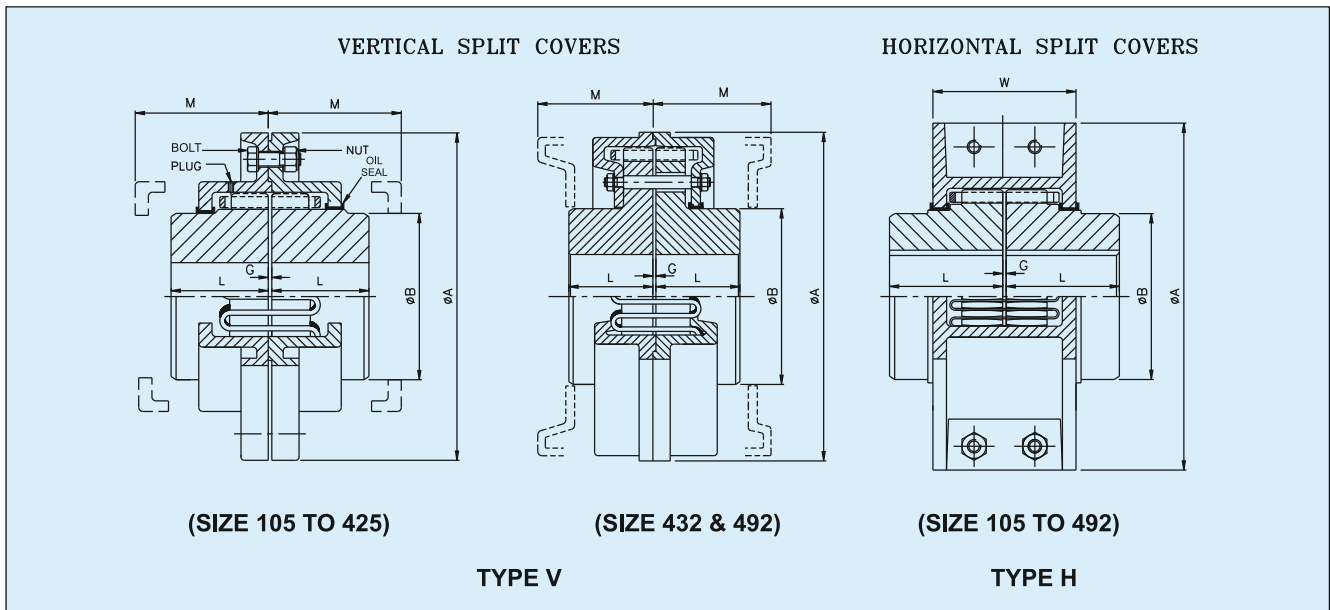

TECHNICAL DATA

Size	kW at 100 rpm	Max. Speed rpm		Bore		Dimensions						Weight kg		
		V	H	Pilot ± 5	Max.	ØA		ØB	G	L	W	M	V	H
						V	H							
LGF-105	0.45	5800	3600	10	29	105	104	45	0.80	38.0	57	53	3	3
LGF-120	0.70	5000	3350	12	38	120	120	58	0.80	38.0	65	53	4	4
LGF-144	1.50	4500	3350	16	42	144	127	62	0.80	44.5	65	60	5	5
LGF-172	2.20	3500	2600	16	58	172	159	87	0.80	51.0	66	60	9	8
LGF-190	3.40	3300	2400	16	58	190	178	85	0.80	51.0	85	80	11	13
LGF-197	4.90	3100	2200	16	65	197	190	100	0.80	57.0	85	80	16	17
LGF-222	7.00	2600	1900	25	80	222	222	120	0.80	63.5	87	80	20	19
LGF-254	9.40	2300	1700	25	95	254	245	143	0.80	70.0	87	81	27	27
LGF-276	13.80	2000	1600	25	110	276	267	165	0.80	89.0	87	81	43	39
LGF-295	26.50	1900	1500	38	104	295	276	155	1.60	102.0	138	129	54	47
LGF-324	33.90	1800	1300	50	124	324	324	187	1.60	101.5	157	148	63	67
LGF-336	48.90	1600	1300	50	124	336	336	184	1.60	101.5	157	148	72	74
LGF-375	67.50	1400	1100	50	148	375	381	222	1.60	114.0	159	148	104	108
LGF-425	93.60	1200	1000	50	170	425	425	254	1.60	127.0	160	148	149	149
LGF-432	179.00	1200	800	75	* 157	432	501	#239	3.20	140.0	180	180	180	234
LGF-492	261.00	1100	700	85	* 173	492	552	#267	3.20	152.5	180	180	216	318

Note :-

- * Max. Bore for 'H' Type LGF - 432 = 202 mm & for LGF - 492 = 234 mm.
- # Dimension B for H type LGF - 432 = 302 mm & for LGF - 492 = 349 mm.
- All dimensions are in mm unless otherwise specified.
- For vertical installation contact RATHI.
- Speeds specified are with standard material of construction, consult manufacturer for higher speeds.
- Weights specified are with max. bore.
- For Inertia, torsional stiffness and for higher sizes consult manufacturer.
- In view of our constant endeavour to improve quality of our products, we reserve the right to alter or change specification without prior notice.
- This document is the intellectual property of Rathi Transpower Pvt. Ltd. and subject to copyright.



Rathi Transpower Pvt Ltd
 Gaia Apex, S. No. 33/2D, Viman Nagar
 Pune 411 014.(INDIA)

Distributor

KB& TRADERS

79/1, APS Complex, Iduvampalayam Road,
 Periyandipalayam Tiruppur-641687, India
 Mobile: 90477 77573, Tel : 0421 4955647
 Email: sales@kbandtraders.com.
 Web: www.kbandtraders.com