

F E A T U R E S

- **Less Backlash.**
- **Compact Assembly.**
- **Larger Bore Capacities.**
- **High Power To Weight Ratio.**
- **Accommodates Angular, Parallel & Axial Misalignments.**
- **Generally used upto 120°C. Can be used for higher temperatures by using proper grade of grease or oil.**

CONSTRUCTION

Full gear type LFG Lovejoy Flexible Gear Coupling consists of two identical toothed hubs, two identical flanged sleeves with internal teeth, a gasket, a set of bolts, nuts and lock washers, lube plugs and two oil / grease retaining seals over the hubs.

NOMENCLATURE

- 1 FORGED HUBS WITH EXTERNAL TEETH
- 2 FORGED SLEEVES WITH INTERNAL TEETH
- 3 FLANGE GASKET
- 4 CLOSE TOLERANCE CONNECTING BOLTS
- 5 LUBRICATION PLUG
- 6 'O' RING

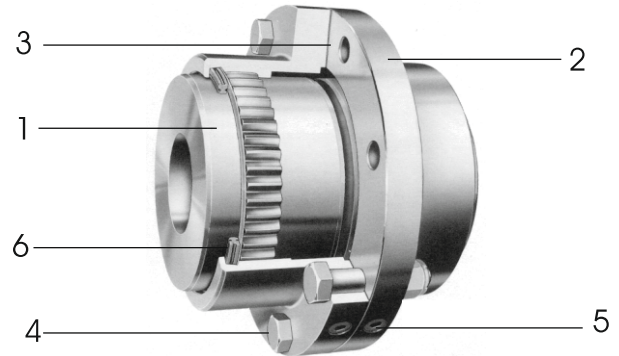

SELECTION PROCEDURE

1. Select an appropriate SERVICE FACTOR from table given below.
2. Multiply the rated running power by the service factor. This gives DESIGN POWER at rated speed (rpm). Convert this to design power at 100 rpm. This is used as a basis for coupling selection.
3. Refer to the rating column and read until the power greater than or equal to the design power at 100 rpm is found. The size of the gear coupling is given in the corresponding first column. Check the max. bore capacities. If required bore size is greater than the max. bore of selected coupling size, then go for higher size to meet the required bore.

SERVICE FACTORS

LOAD	DRIVEN EQUIPMENT	TYPE OF DRIVE	
		Motor or Turbine	Reciprocating Engine
Uniform	Centrifugal Pumps, Conveyors - Even Loaded, Exciters, Fans and Blowers - Light Duty, Generators - Even Loaded & Mixers - Liquid.	1	1.5
Light	Centrifugal Pumps, Generators - Pulsating Load, Grinders, Hydraulic Pumps, Kilns, Line Shafting, Machine Tools, Oscillating Pumps, Textile Machinery & Woodworking Machinery.	1.5	2
Medium	Air compressors - Multi - Cylinder, Ball and Rod Mills, Cranes, Elevators, Hoists, Punch Presses, Reciprocating pumps, Shears, Ship Drives & Welding Generators.	2	2.5
Heavy	Air Compressors - Single Cylinder, Dredges, Drilling Rigs, Mine Machinery, Rolling Mill Drives & Rubber Mixers.	2.5	3
Extreme	Ore Crushers, Bar Stock Shears & Vibrating Conveyors.	3	4

FEATURES

Standard full flexible gear coupling TYPE LFG accommodates angular & parallel misalignments or a combination of both as well as axial misalignment (end float). Ideal for all horizontal, close coupled applications including fans, overhead cranes, conveyors, steel & paper mill equipments. One or both the hubs can be easily reversed for more than normal shafts separation applications.

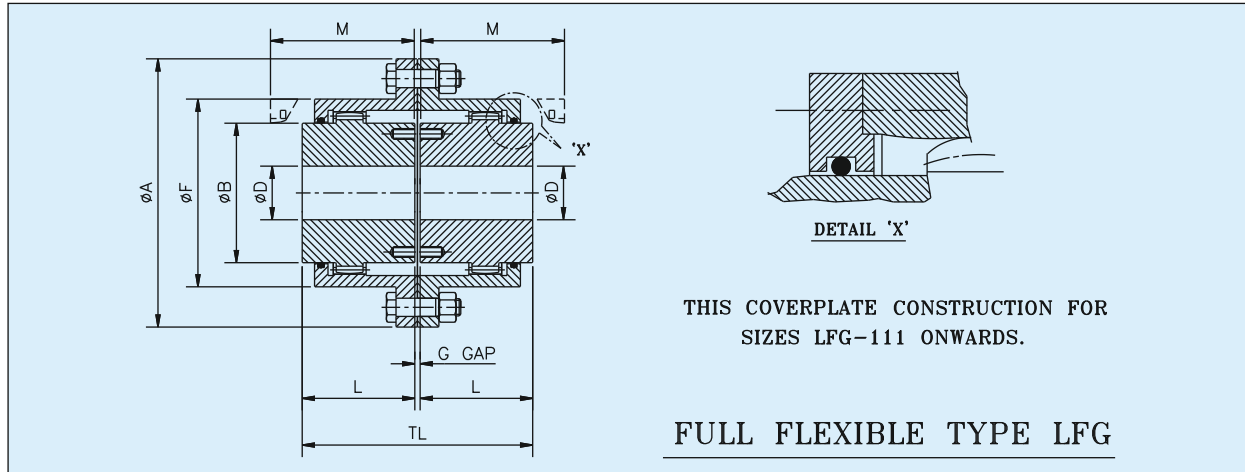

TECHNICAL DATA

Size	kW at 100 rpm	Rated Torque Nm	Max. rpm	Bore ϕD		ϕA	ϕB	ϕF	G	L	M	TL	#	
				PB	Max.								Wt. kg	M.I.(WR ²) kg-m ²
LFG-100	6	559	7600	13	35	120	50	75	3	45	54	93	4.1	0.006
LFG-101	12	1127	6730	14	50	170	65	110	5	55	67	115	10.6	0.029
LFG-102	29	2804	6150	20	65	185	85	125	5	70	83	145	15.4	0.046
LFG-103	53	5047	5200	30	80	220	105	150	5	85	103	175	26.0	0.110
LFG-104	100	9557	4580	40	100	250	130	175	5	105	124	215	40.0	0.213
LFG-105	152.94	14605	3950	46	115	290	155	200	10	110	136	230	60.0	0.445
LFG-106	235	22444	3550	50	125	320	175	230	10	125	152	260	84.0	0.745
LFG-107	412	39303	3270	60	145	350	205	260	10	140	174	290	113.4	1.21
LFG-108	529	50472	3015	70	165	380	230	290	10	155	187	320	158.0	2.04
LFG-109	658	62821	2650	80	190	430	250	330	10	165	196	340	210.0	3.46
LFG-110	963	91923	2330	100	230	490	310	390	10	180	216	370	290.0	5.55
LFG-111	1289	123065	2100	110	260	545	350	445	10	200	245	410	545.0	15.25
LFG-112	1723	164516	1940	150	300	590	400	490	10	240	289	490	716.0	24.30
LFG-113	2908	277694	1600	160	330	680	440	555	15	260	312	535	984.0	43.21
LFG-114	4019	383786	1500	200	370	730	500	610	15	280	341	575	1219.0	64.84
LFG-115	4812	459515	1400	230	410	780	540	660	15	320	385	655	1566.0	97.30
LFG-116	7028	671165	1200	260	455	900	625	755	20	350	423	720	2246.0	183.66
LFG-117	9997	954665	1100	300	520	1000	720	855	20	400	489	820	3260.0	338.05
LFG-118	13236	1263938	1000	320	620	1100	810	950	20	450	533	920	4680.0	600.41
LFG-119	17454	1666744	900	300	710	1250	910	1050	30	485	559	1000	6283.0	955.96

- All dimensions are in mm unless otherwise specified.
- Spacer couplings, Brake drum, Brake disc, Shear pin, Floating shaft couplings are available.
- LFG Gear couplings are designed for maximum misalignment of 1.5 deg. per gear mesh. recommended initial misalignment is 0.37 deg. per gear mesh.
- For vertical installation contact RATHI.
- For all max. bore conditions, only single rectangular keyway is applicable.
- # Weight & Moment of Inertia are at pilot bore.

FEATURES

- Standard half flexible gear coupling TYPE LHG cannot accommodate parallel misalignment.
- Used primarily with floating shaft assemblies. Extensively used for cross traverse and long travel line shaft drives.

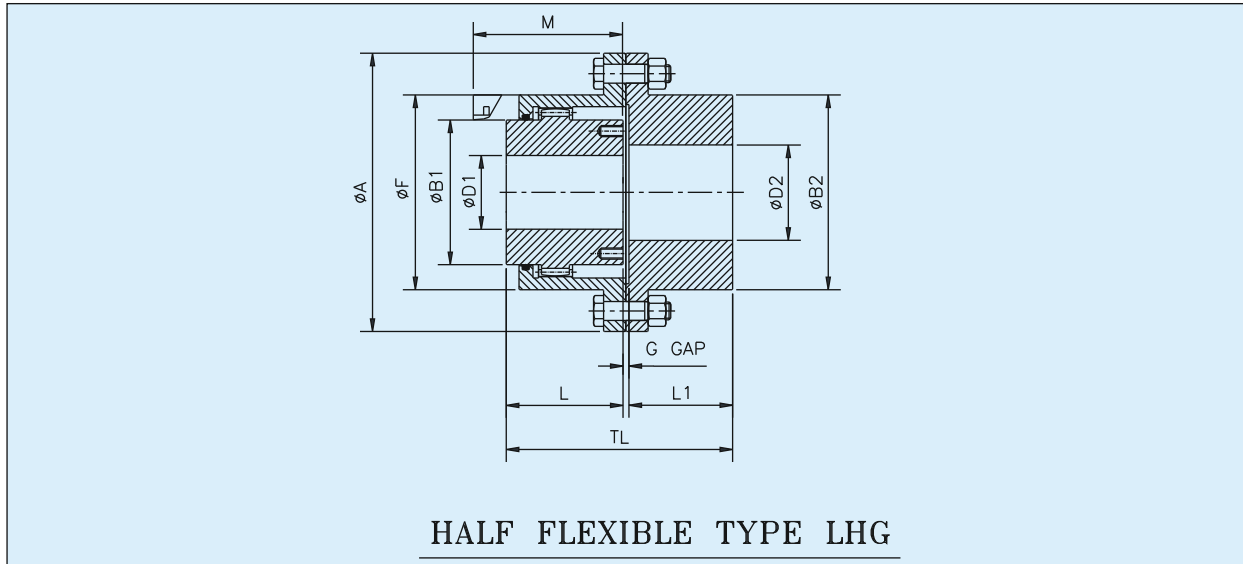

TECHNICAL DATA

Size	kW at 100 rpm	Rated Torque Nm	Max. rpm	Bore						ØA	ØB1	ØB2	ØF	G	L	L1	M	TL	#	
				PB	Max.		Wt. kg	M.I. (WR ²) ₂ kg-m ²												
					ØD1	ØD2														
LHG-100	6	559	7600	13	35	45	120	50	65	75	3	45	45	54	93	4.2	0.006			
LHG-101	12	1127	6730	14	50	60	170	65	85	110	5	55	55	67	115	10.1	0.027			
LHG-102	29	2804	6150	20	65	75	185	85	110	125	5	70	70	83	145	15.2	0.045			
LHG-103	53	5047	5200	30	80	90	220	105	130	150	5	85	85	103	175	25.3	0.106			
LHG-104	100	9557	4580	40	100	110	250	130	160	175	5	105	105	124	215	40.4	0.211			
LHG-105	153	14605	3950	46	115	130	290	155	185	200	10	110	110	136	230	60.4	0.440			
LHG-106	235	22444	3550	50	125	150	320	175	215	230	10	125	125	152	260	85.5	0.747			
LHG-107	412	39303	3270	60	145	170	350	205	240	260	10	140	140	174	290	115.0	1.20			
LHG-108	529	50472	3015	70	165	200	380	230	285	290	10	155	155	187	320	164.3	2.10			
LHG-109	658	62821	2650	80	190	220	430	250	315	330	10	165	165	196	340	216.7	3.52			
LHG-110	963	91923	2330	100	230	260	490	310	370	390	10	180	180	216	370	317.0	6.86			

- All dimensions are in mm unless otherwise specified.
- Spacer couplings, Brake drum, Brake disc, Shear pin, Floating shaft couplings are available.
- LHG Gear couplings are designed for maximum misalignment of 1.5 deg. per gear mesh. recommended initial misalignment is 0.37 deg. per gear mesh.
- For vertical installation contact RATHI.
- For all max. bore conditions, only single rectangular keyway is applicable.
- # Weight & Moment of Inertia are at pilot bore.

- In view of our constant endeavour to improve quality of our products, we reserve the right to alter or change specifications without prior notice.
- This document is the intellectual property of Rathi Transpower Pvt. Ltd. and subject to copyright.



Rathi Transpower Pvt Ltd
Gaia Apex, S. No. 33/2D, Viman Nagar
Pune 411 014.(INDIA)

Distributor



79/1, APS Complex, Iduvampalayam Road,
Periyandipalayam Tiruppur-641687, India
Mobile: 90477 77573, Tel : 0421 4955647
Email: sales@kbandtraders.com.
Web: www.kbandtraders.com