

Diaphragm Type Homogenizer Pressure Gauge

DSHO

Delta offers homogeniser diaphragm seals to suit most brands of homogeniser pumps. A unique built in dampening device is incorporated into the seal to help protect the instrument from premature failure due to high pressure spikes. These seals can be fitted direct or via a capillary. . It is reliable, easy to clean and works on all medias which can be homogenized.

Applications :

These gauges are being used in applications where hygiene is of prime importance like Dairy Food, Beverages & Pharmaceutical Industries.



Special Features :

- ★ Fillable version facilitate usage in vibration zones to avoid damages to its mechanism.
- ★ Suitable to use in dairy homogenizer machines.

Specifications

Standard Version:100mm, 150mm

Accuracy	class 1,6 as per EN 837-1.
Ambient temperature	-25...+65 °C.
Process temperature	-20...+120 °C. Max 150 °C for 1 hour during cleaning stage
Working pressure	max 60% of full scale
Overpressure limit	not available.
Seal fill	oil for food service.
Case filling liquid	Dampening Liquid glycerine 98% (For Fiiled Version)
Protection	IP 67.
Process connection	AISI 316L st.st.
Diaphragm	AISI316L, Hastelloy C .
Welding	AISI 316L TIG
Flange and screw nut	AISI 316.
Case & Bezel	AISI 304 st.st.
Window	Plexiglas.
Movement	SS 304
Dial	aluminium, white with black markings. Pointer: aluminium black anodized.
Gasket, blow out vent and filling plug	EPDM

Dimension :

TYPE H01

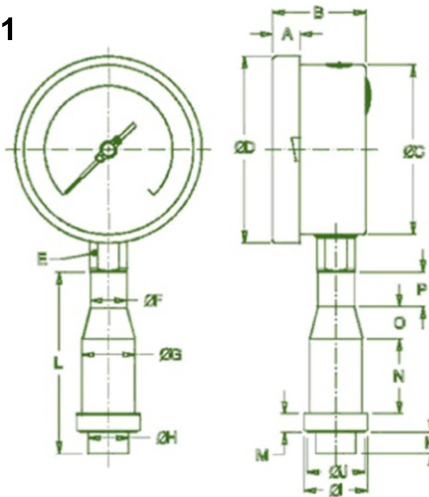

WITHOUT FLANGE CONNECTION

NS	A	B	ØC	ØD	E	ØF	ØG	ØH	Øi	Øj	K	L	M	N	O	P
100	12.5	48	100	110	22	21.5	23.5	15	37.5	34	12	106.5	11	44.5	19	20
150	15	49	149	161	22	21.5	23.5	15	37.5	34	12	106.5	11	44.5	19	20

TYPE H02

FLANGE CONNECTION

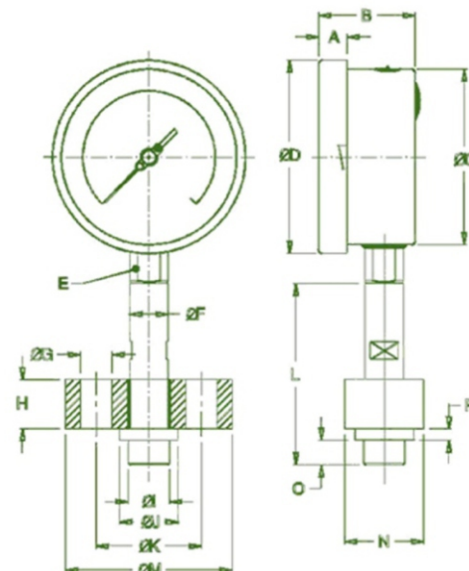

NS	A	B	ØC	ØD	E	ØF	ØG	H	ØI	ØJ	ØK	L	ØM	N	O	P
150	12.5	48	100	110	22	22	18	28	23.5	33.3	60	102	95	45	13	6.5
150	15	49	149	161	22	22	18	28	23.5	33.3	60	102	95	45	13	6.5

All Dimensions are in mm, Drawings are not to scale

WITHOUT FLANGE CONNECTION

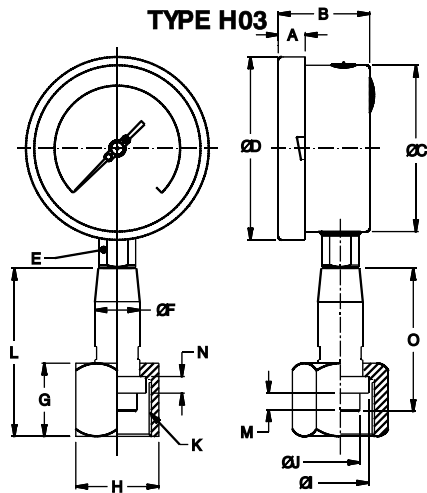

NS	A	B	ØC	ØD	E	ØF	ØG	ØH	Øi	Øj	K	L	M	N	O	P
150	12.5	48	100	110	22	21.5	23.5	15	37.5	34	12	106.5	11	44.5	19	20
150	15	49	149	161	22	21.5	23.5	15	37.5	34	12	106.5	11	44.5	19	20

HOW TO ORDER

Basic Model:	CODE	C	D	PGH
	Nominal Size(mm)	100 mm	150 mm	C
Type Of Mounting:	1.	Direct Bottom Entry		
Gauge Connection:				H01
H01	Flange	H03	1¼" BSP (F)	
H02	With Out Flange			
RANGE (in kg/cm ² or bar)				0-250
0/160	0/250	0/400	0/600	0/1000
Options:				RH
PW	Five Point Calibration Certificate	SX	SS Tag Plate	
RH	Custom Designed Dial			

Ordering Example : PGH - C - H01 - 0-250 - RH

Note : Due to continuous improvement, the specification may vary from time to time.